

# LONDON



~220-240V  
50-60Hz



IP54



E27

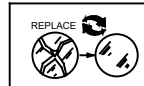

REPLACE



Art.: 4012

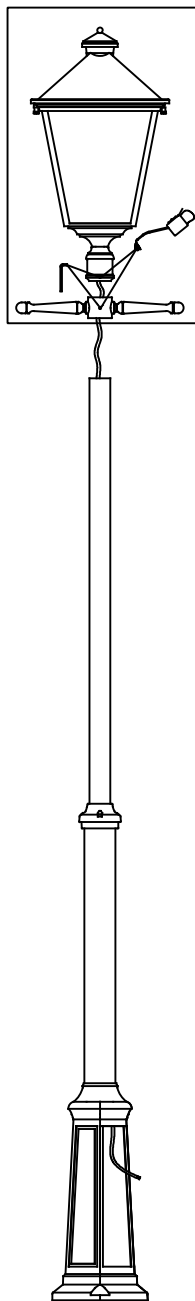
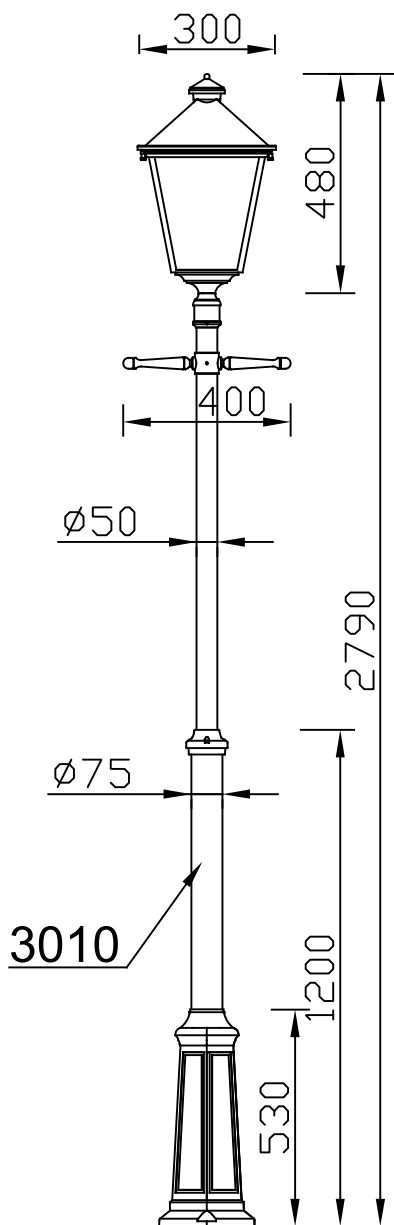

Art.3010

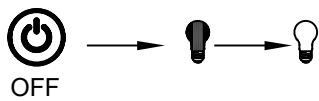
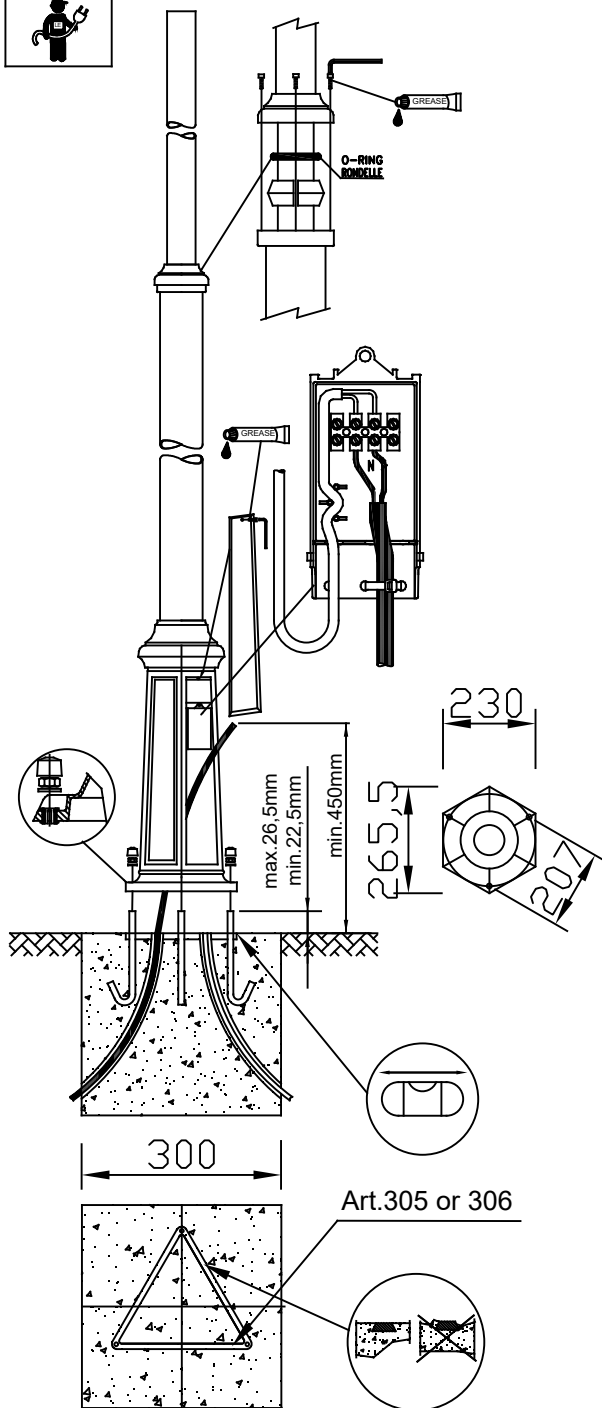

OFF

E27



LED Max.11W

max.110mm  
A Ø55-Ø60

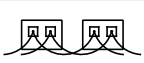
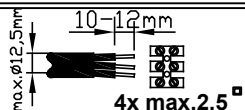
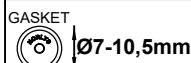

max.4x2,5²



(ENG) The light source contained in this luminaire shall only be replaced by the manufacturer or his service agent or a similar qualified person.

(NOR) Installasjon skal utføres av en autorisert installatør/fagmann.

(SWE) All installation skall utföras av auktoriserad elinstallatör.

(DE) Die Montage und der Austausch der in dieser Leuchte enthaltenen Lichtquelle dürfen nur durch den Hersteller oder seinen Kundendienst oder eine gleich qualifizierte Person ausgeführt werden. Bitte lokale Bestimmungen beachten!

(FR) Le montage et le remplacement de la source lumineuse du luminaire doit être fait uniquement par le fabricant, un agent de maintenance ou une personne ayant des qualifications similaires. Merci de respecter la réglementation nationale.

(PL) Źródło światła zastosowane w tej oprawie oświetleniowej powinno być wymieniane wyłącznie przez producenta lub jego przedstawiciela serwisowego, lub podobnie wykwalifikowaną osobę.



(ENG) Turn off the power before replacing the light source.

(NOR) Skru av strømmen før skifte av lyskilde.

(SWE) Koppla bort strömmen innan byte av ljuskälla sker.

(DE) Schalten Sie die Stromversorgung aus, bevor Sie die Lichtquelle austauschen.

(FR) Éteindre le courant avant de remplacer la source lumineuse.

(PL) Wyłącz zasilanie przed wymianą źródła światła.

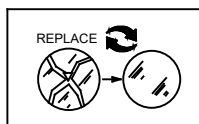

(ENG) Replace any cracked protective screen.

(NOR) Sprukket glass må skiftes

(SWE) Sprucket glas måste bytas.

(DE) Ersetzen Sie jeden beschädigten Schutzschirm.

(FR) Remplacer les écrans de protection fissurés.

(PL) Wymienić każdy pęknięty ekran ochronny.

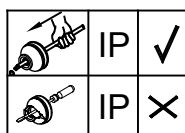

(SWE) Använd endast 7-10,5mm Ø kabel för genomträngning av packningar. Skador orsakade av andra typer av verktyg kan sänka IP-klassning på armaturen. Felaktig installation kan orsaka garantiförlust.